CROWN

*Tow
Tractors*

*Series:
TR
TWR
TW*





Crown Tow Tractors: Proven Pulling Power

When you analyze the facts concerning tow tractors, it quickly becomes obvious that their productivity and durability are dependent on one major component: the drive unit. If they can't pull their load – or, worse yet, keep breaking down – efficiency and economy go out the window.

With the Crown series of tow tractors, you get a drive unit that is larger and heavier than any other in this type of truck. In fact, it is the same one we use in our stockpickers that go 30 feet in the air. This drive unit – along with its massive 13½-inch drive tire – is a proven winner.

Of course, Crown tow tractors have more than this to offer. There is also the time-tested multiple-function control handle – the most imitated in the world. And, the fatigue-fighting operator's compartment ensures productivity from your workers for the whole shift.

Crown offers three basic models of tow tractors, all with 24-volt electrical systems: the Series TR rider, the Series TWR walkie/rider, and the Series TW walkie. Any one of these, when fitted to the proper application, can boost your productivity and uptime.



Largest Tugger Drive Unit

The heart of Crown tow tractors is the drive unit – the largest one made for this type of truck. It is designed to withstand the jerks and jolts that are inevitable when pulling heavy loads.

This is an all-gear unit, with each Crown-cut gear mounted on ball or roller bearings. The unit has tapered roller bearings at the top, while the bottom sits in a hardened steel roller race held secure by four shock-mounted rollers.



Largest Tire; Less Downtime

Crown uses a 13½-inch diameter drive tire on its tow tractors, while most competitive trucks' tires are usually 10½ inches or less. A drive tire this big can help absorb shocks to the drive train componentry caused by rough and uneven floors. The result: less downtime.

Comfortable Compartment

An operator is only as productive as his equipment allows him to be. For this reason, Crown made the driver's compartment as comfortable and efficient as possible.

The floor, for example, is thickly padded to help fight fatigue in the operator's feet and legs. The backrest, too, is padded and also tilts back slightly so that he assumes a natural position and his hands rest comfortably on the control handle.



Time-Tested Control Handle

The control handles on Crown tow tractors' help make any task easier. The TR's handle (shown above) is extra wide for steering leverage in a turn, and so that the operator can guide it while walking along either side during order picking. And, the TWR's handle flips over to the front of the truck so it can be used as a walkie.

Dual twist grips control three forward and reverse speeds (stepless SCR is optional). To prevent high-speed operation in congested areas, a third-speed cutout switch on the TW and TWR can be actuated. Similarly, top speed on the TR can only be achieved by depressing a foot pedal.

Braking on TR models is controlled by hand-operated squeeze levers that can be applied from either side of the tractor. To brake the TWR and TW models, the operator must either push down or lift up the spring-loaded handle. Also, the brakes are applied automatically when the handle is released by the driver.

Also, a mechanical control disengages the brake on the TWR, allowing the truck to coast for convenient order picking. The TR is designed to coast unless pressure is applied to the brake levers.



Crown Tow Tractors



Series TR



Series TWR



Series TW

Coupler Selection

An adjustable hitch plate allows all types of hitches to be adjusted in 1.75-inch increments. Four different types of hitches are offered: automatic, pintle, eye, or pin and clevis.

Pin & Clevis

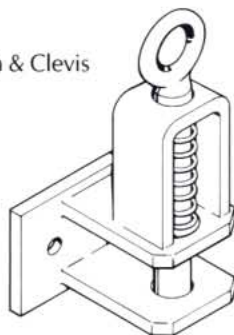

Automatic

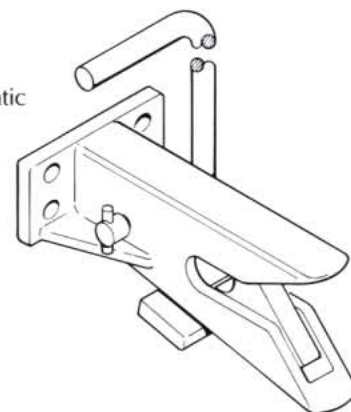

Pintle

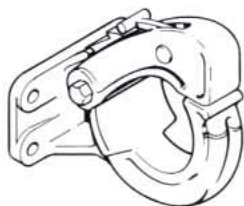

Eye

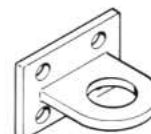

CROWN

New Bremen, Ohio 45869 USA
Phone: 419/629-2311
Telex: 24-2425